

## GENERAL INSTALLATION INSTRUCTIONS - ADA Accessible Hapsburg Table Set

PLEASE READ THESE STEPS BEFORE PROCEEDING

Included with your Hapsburg Accessible Table Set is the following hardware:

- Thirty-six (36) 1/2" Stainless Steel Flat Washers
- Eighteen (18) 1/2" Stainless Steel Nylon Lock Nuts
- Two (2) 1/2" x 4" Stainless Steel Hex Head Cap Screws
- Sixteen (16) 1/2" x 1 1/2" Stainless Steel Hex Head Cap Screws



Please abide by the following installation instructions:

### Brace:

1. Place brace with angles across from each other.
2. Then align the brace with the holes with the holes in the angles of the other brace.
3. Place a 1/2" washer on a 1/2" x 4" cap screw and insert it through the holes in both braces.
4. Place 1/2" washer over threaded end of cap screw, then add 1/2" nut. **(Do not tighten on this step)**

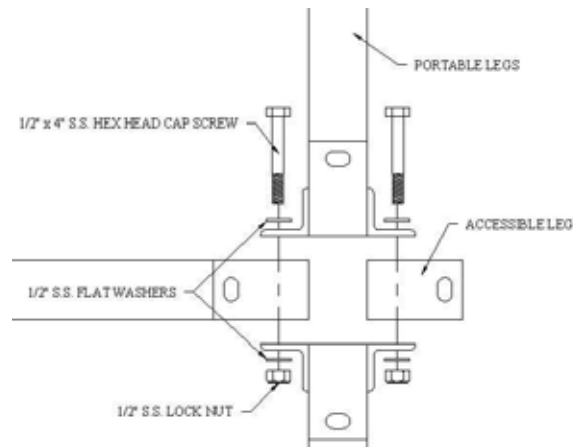

**Table:**

1. Place tabletop on pedestal, aligning the holes on the underside of the tabletop with the holes on the pedestal.
2. Add 1/2" washer to 1/2" x 1 1/2" cap screw and insert down through the hole in the table and pedestal.
3. Slide 1/2" washer over exposed threads and add 1/2" lock nut and tighten.
4. After tightening table top down, tighten brace screws.

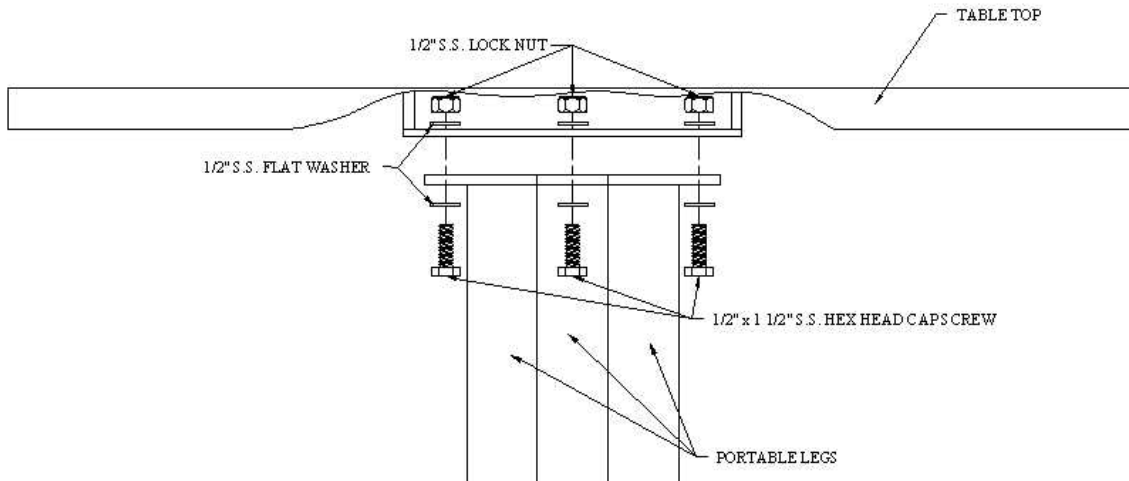

**Seat:**

1. Place seat on top of pedestal, matching up holes.
2. Add 1/2" washer to 1/2" x 1 1/2" cap screw and insert through holes in seat and pedestal.
3. Slide 1/2" washer over exposed threads and add 1/2" lock nut and tighten.

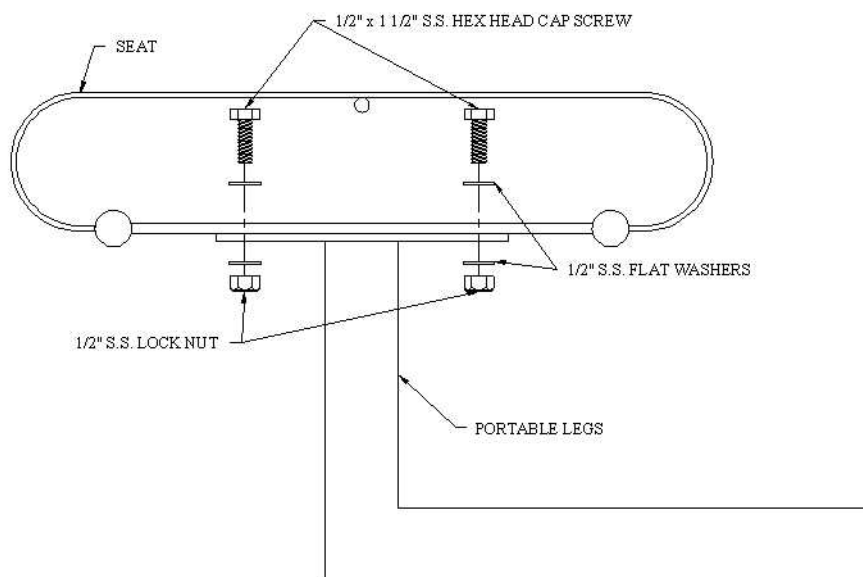

\*After tightening all bolts, table set must be bolted to the ground.